

Our Ref: 2078

25 February 2016

Clenergy Australia
11/20 Duerdin Street
Clayton VIC 3168



Array Frame Engineering Certificate

Installation of PV-ezRack[®] SolarRoof Adjustable Tilt Legs with ECO-Rails

Gamcorp (Melbourne) Pty Ltd, being Structural Engineers within the meaning of Australian Building Regulations, have carried out a structural design check of PV-ezRack[®] SolarRoof Adjustable Tilt Legs installation within Australia. The design check has been based on the information in the PV-ezRack SolarRoof Adjustable Tilt Legs_Code Compliant Installation Guide_AU_V3.3 and schematic drawings of the system components by Clenergy (Xiamen) Technology Co. Ltd, provided by Clenergy Australia.

We find the Installation of PV-ezRack[®] SolarRoof Adjustable Tilt Legs installation to be structurally sufficient for Australian use based on the following conditions:

- Wind Loads to AS/NZ1170.2:2011 Admt 2-2012
- Wind Region A, B, C, D
- Wind Terrain Category 2 & 3
- Wind average recurrence interval of 100 years
- Maximum Building height 20 m
- Max. Solar Panel Dimensions 2000x1000 mm

Refer to attached summary table for interface spacing.

Construction is to be carried out strictly in accordance with the manufacturers instructions. This work was designed in accordance with the provisions of Australian Building Regulations and in accordance with sound, widely accepted engineering principles.

Yours faithfully,
Gamcorp (Melbourne) Pty Ltd



Martin Gamble
Managing Director
MAICD



Mudi Ariyaratna
B.Eng(Civil)(Hons)Monash, M.Eng&Mgt, MIEAust,
CPEng, NPER, RBP EC-39699, RPEQ- 15899

Structural Design Documentation

PV-ezRack® SolarRoof Adjustable Tilt Legs Spacing Table
According to AS 1170.2011 for all wind regions
with ECO-Rails
Within Australia
Terrain Category 2

For: Clenergy Australia



Job Number: 2078
Date: 25 February 2016



COPYRIGHT: The concepts and information contained in this document are the property of Gamcorp (Melbourne) Pty Ltd. Use or copying of this document in whole or in part without the written permission of Gamcorp constitutes an infringement of copyright.

LIMITATION: This report has been prepared on behalf of and for the exclusive use of Gamcorp (Melbourne) Pty Ltd's Client, and is subject to and issued in connection with the provisions of the agreement between Gamcorp (Melbourne) Pty Ltd and its Client. Gamcorp (Melbourne) Pty Ltd accepts no liability or responsibility whatsoever for or in respect of any use of or reliance upon this report by any third party.



1/19 Anthony Drive
Mount Waverley VIC 3149
Tel: 03 9803 9533
Fax: 03 9802 9125
melbourne@gamcorp.com.au
www.gamcorp.com.au

ISO 9001:2008 Registered Firm
Certificate No: AU1222

Job No: 2078
Client: Clenergy Australia
Project: PV-ezRack® SolarRoof Adjustable Tilt Legs Spacing Table

Address: Within Australia

Australian Standards

AS 1170. 2011 – Structural Design Actions
 Part 0 – General Principles
 Part 1 – Permanent imposed and other actions
 Part 2 – Wind Actions
 Part 3 – Snow and Ice Actions
AS 1252 – High Strength Structural Bolting
AS 3600 – Concrete Structures
AS 4055 – Wind Loads for Housing
AS 4100 – Steel Structures
AS 4600 – Cold-Formed Steel Structures

Wind Terrain Category: WTC 2

Designed: M.A

Date: Feb-16

Client: **Clenergy Australia**
 Project: **PV-ezRack® SolarRoof Adjust. Tilt Legs Spacing Table**
 Address: **Within Australia**
 Designed: **M.A**

Job: **2078**
 Date: **Feb-16**

REV K

PV-ezRack® SolarRoof Frame spacing Table for Adjustable Tilt Leg

Type of Rail ER-R-ECO
 Type of Interface ER-TL (Adjustable Tilt Leg)
 Solar Panel Dimension 2mx1m
 Terrain category 2

Type of Interface 10°-15° Adjustable Tilt Leg
 Roof Angle (Φ) - ≤10°

Wind Region	Building Height - H (m)															
	H≤5				5<H≤10				10<H≤15				15<H≤20			
	Corner	Edge	Intermediate	Internal	Corner	Edge	Intermediate	Internal	Corner	Edge	Intermediate	Internal	Corner	Edge	Intermediate	Internal
A	1160	1340	1465	1675	1045	1270	1385	1570	990	1235	1345	1525	930	1200	1325	1495
B	960	1220	1430	1645	785	1100	1285	1545	710	1045	1220	1495	670	1015	1180	1470
C	590	900	1107	1385	485	740	1000	1245	440	670	905	1180	415	630	850	1145
D	405	615	830	1130	335	505	680	1025	300	460	615	945	285	432	580	890

Type of Interface 15°-30° Adjustable Tilt Leg
 Roof Angle (Φ) - ≤10°

Wind Region	Building Height - H (m)															
	H≤5				5<H≤10				10<H≤15				15<H≤20			
	Corner	Edge	Intermediate	Internal	Corner	Edge	Intermediate	Internal	Corner	Edge	Intermediate	Internal	Corner	Edge	Intermediate	Internal
A	720	1050	1230	1390	590	905	1110	1310	535	815	1050	1275	505	770	1020	1255
B	518	790	1035	1290	425	650	880	1165	385	585	790	1105	365	555	745	1070
C	322	490	660	1005	265	405	540	825	240	365	490	745	230	345	460	700
D	225	340	450	690	185	280	370	565	165	250	335	510	160	240	320	480

Type of Interface 30° Adjustable Tilt Leg
 Roof Angle (Φ) - ≤10°

Wind Region	Building Height - H (m)															
	H≤5				5<H≤10				10<H≤15				15<H≤20			
	Corner	Edge	Intermediate	Internal	Corner	Edge	Intermediate	Internal	Corner	Edge	Intermediate	Internal	Corner	Edge	Intermediate	Internal
A	585	890	1100	1305	480	730	990	1240	435	660	895	1175	410	625	840	1140
B	420	640	865	1155	350	530	710	1045	315	475	640	985	300	450	605	925
C	265	400	535	815	220	330	440	670	195	295	400	605	185	280	375	570
D	180	275	370	560	150	230	305	460	135	205	275	415	130	195	260	390

Client: **Clenergy Australia**
 Project: **PV-ezRack® SolarRoof Adjust. Tilt Legs Spacing Table**
 Address: **Within Australia**
 Designed: **M.A**

Job: **2078**
 Date: **Feb-16**

REV K

PV-ezRack® SolarRoof Frame spacing Table for Adjustable Reverse Tilt Leg

Type of Rail ER-R-ECO
 Type of Interface ER-TL (Adjustable Tilt Leg)
 Solar Panel Dimension 2mx1m
 Terrain category 2

Type of Interface 30°-60° Adjustable Tilt Leg
 Roof Angle (Φ) - ≤10°

Wind Region	Building Height - H (m)															
	H≤5				5<H≤10				10<H≤15				15<H≤20			
	Corner	Edge	Intermediate	Internal	Corner	Edge	Intermediate	Internal	Corner	Edge	Intermediate	Internal	Corner	Edge	Intermediate	Internal
A	585	890	1100	1305	480	730	990	1240	435	660	895	1175	410	625	840	1140
B	420	640	865	1155	350	530	710	1045	315	475	640	985	300	450	605	925
C	265	400	535	815	220	330	440	670	195	295	400	605	185	280	375	570
D	180	275	370	560	150	230	305	460	135	205	275	415	130	195	260	390

Type of Interface 30°-60° Adjustable Tilt Leg
 Roof Angle (Φ) - ≤20°

Wind Region	Building Height - H (m)															
	H≤5				5<H≤10				10<H≤15				15<H≤20			
	Corner	Edge	Intermediate	Internal	Corner	Edge	Intermediate	Internal	Corner	Edge	Intermediate	Internal	Corner	Edge	Intermediate	Internal
A	715	1050	1225	1380	590	900	1105	1310	530	812	1050	1270	505	765	1020	1250
B	515	790	1035	1285	425	645	875	1160	385	585	790	1100	365	550	745	1070
C	320	485	655	1002	265	400	540	825	240	365	490	745	230	345	460	700
D	220	335	450	685	180	275	370	565	166	250	335	510	160	235	315	480

Type of Interface 30°-60° Adjustable Tilt Leg
 Roof Angle (Φ) - ≤30°

Wind Region	Building Height - H (m)															
	H≤5				5<H≤10				10<H≤15				15<H≤20			
	Corner	Edge	Intermediate	Internal	Corner	Edge	Intermediate	Internal	Corner	Edge	Intermediate	Internal	Corner	Edge	Intermediate	Internal
A	1150	1335	1455	1655	1040	1265	1375	1555	980	1230	1335	1505	925	1190	1315	1480
B	950	1210	1415	1625	780	1095	1275	1530	705	1040	1210	1485	665	1005	1175	1455
C	585	895	1100	1375	485	735	995	1240	435	665	895	1175	415	625	845	1140
D	405	610	825	1125	335	505	680	1020	300	455	615	935	285	430	580	880

Client: **Clenergy Australia**
 Project: **PV-ezRack® SolarRoof Adjust. Tilt Legs Spacing Table**
 Address: **Within Australia**
 Designed: **M.A**

Job: **2078**
 Date: **Feb-16**

REV K

General Notes			
Note 1	Screws minimum embedment length into timber 35 mm		
Note 2	Recommended screws		
	Metal Purlins/Battens		Fasteners to use
	0.55 mm – 1.5 mm		M6-11 TPI RoofZips
	1.9 mm		M6-11 TPI RoofZips OR 12g-14 TPI Teks screws
	2.4 mm and Above		12g-24 TPI Teks screws
	Wood purlins and Rafter		Fasteners to use
	Pine and Hardwood (35mm embedment and above)		M6 (12g) with 10 TPI
Note 3	Following components are satisfied to use according to AS1170.2011		
	Components	Part Number	Description
	MT-base Rail	ER-R-MT2560	MT-Rail 2560 mm
	Corrugated Adapter	ER-AD-C110	Adapter for corrugated iron roof
	Tilt Legs	ER-TL-30	Tilt Legs Kit fixed 30° (front and back leg)
	Hanger Bolt	ER-HB-200/WOMP	Hanger Bolt without mounting plate M10x200. Fixed to timber purlin only
	Roof extender	ER-RE-200	Roof Hook Extender 200mm
Note 4	For adjustable tilting leg, Maximum back leg angle to horizontal	-	90°
	Minimum back leg angle to horizontal	-	30°
Note 5	Refer Figure 5.3 of AS/NZS 1170.2:2012 for definition of roof zones.		
Note 6	For PV panels with length of 1700mm, increase the spacing by 15%.		

Structural Design Documentation

PV-ezRack® SolarRoof Adjustable Tilt Legs Spacing Table
According to AS 1170.2011 for all wind regions
with ECO-Rails
Within Australia
Terrain Category 3

For: Clenergy Australia



Job Number: 2078
Date: 25 February 2016



COPYRIGHT: The concepts and information contained in this document are the property of Gamcorp (Melbourne) Pty Ltd. Use or copying of this document in whole or in part without the written permission of Gamcorp constitutes an infringement of copyright.

LIMITATION: This report has been prepared on behalf of and for the exclusive use of Gamcorp (Melbourne) Pty Ltd's Client, and is subject to and issued in connection with the provisions of the agreement between Gamcorp (Melbourne) Pty Ltd and its Client. Gamcorp (Melbourne) Pty Ltd accepts no liability or responsibility whatsoever for or in respect of any use of or reliance upon this report by any third party.



1/19 Anthony Drive
Mount Waverley VIC 3149
Tel: 03 9803 9533
Fax: 03 9802 9125
melbourne@gamcorp.com.au
www.gamcorp.com.au

ISO 9001:2008 Registered Firm
Certificate No: AU1222

Job No: 2078
Client: Clenergy Australia
Project: PV-ezRack® SolarRoof Adjustable Tilt Legs Spacing Table

Address: Within Australia

Australian Standards

AS 1170. 2011 – Structural Design Actions
 Part 0 – General Principles
 Part 1 – Permanent imposed and other actions
 Part 2 – Wind Actions
 Part 3 – Snow and Ice Actions
AS 1252 – High Strength Structural Bolting
AS 3600 – Concrete Structures
AS 4055 – Wind Loads for Housing
AS 4100 – Steel Structures
AS 4600 – Cold-Formed Steel Structures

Wind Terrain Category: WTC 3

Designed: M.A

Date: Feb-16

Client: **Clenergy Australia**
 Project: **PV-ezRack® SolarRoof Adjust. Tilt Legs Spacing Table**
 Address: **Within Australia**
 Designed: **M.A**

Job: 2078
 Date: **Feb-16**

REV K

PV-ezRack® SolarRoof Frame spacing Table for Adjustable Tilt Leg

Type of Rail ER-R-ECO
 Type of Interface ER-TL (Adjustable Tilt Leg)
 Solar Panel Dimension 2mx1m
 Terrain category 3

 Type of Interface 10°-15° Adjustable Tilt Leg
 Roof Angle (Φ) - ≤10°

Wind Region	Building Height - H (m)															
	H≤5				5<H≤10				10<H≤15				15<H≤20			
	Corner	Edge	Intermediate	Internal	Corner	Edge	Intermediate	Internal	Corner	Edge	Intermediate	Internal	Corner	Edge	Intermediate	Internal
A	1260	1420	1555	1800	1260	1420	1555	1800	1185	1360	1485	1705	1120	1320	1435	1640
B	1080	1350	1525	1760	1080	1350	1525	1760	1000	1250	1460	1670	895	1175	1380	1610
C	715	1045	1225	1535	715	1045	1225	1535	620	950	1135	1420	550	845	1070	1335
D	490	745	1005	1250	490	745	1005	1250	425	645	870	1160	380	575	775	1090

Type of Interface 15°-30° Adjustable Tilt Leg
 Roof Angle (Φ) - ≤10°

Wind Region	Building Height - H (m)															
	H≤5				5<H≤10				10<H≤15				15<H≤20			
	Corner	Edge	Intermediate	Internal	Corner	Edge	Intermediate	Internal	Corner	Edge	Intermediate	Internal	Corner	Edge	Intermediate	Internal
A	875	1160	1300	1465	875	1160	1300	1465	755	1075	1250	1405	670	1015	1185	1360
B	625	960	1145	1430	625	960	1145	1430	542	830	1060	1325	485	740	1000	1245
C	390	591	790	1110	390	591	790	1110	335	510	690	1030	300	455	615	940
D	270	405	545	835	270	405	545	835	232	350	470	720	210	315	420	640

Type of Interface 30°-60° Adjustable Tilt Leg
 Roof Angle (Φ) - ≤10°

Wind Region	Building Height - H (m)															
	H≤5				5<H≤10				10<H≤15				15<H≤20			
	Corner	Edge	Intermediate	Internal	Corner	Edge	Intermediate	Internal	Corner	Edge	Intermediate	Internal	Corner	Edge	Intermediate	Internal
A	705	1040	1215	1380	705	1040	1215	1380	610	935	1125	1325	545	830	1065	1280
B	510	775	1025	1280	510	775	1025	1280	440	670	910	1185	395	600	810	1115
C	315	480	645	990	315	480	645	990	275	415	560	855	245	370	500	760
D	220	330	445	675	220	330	445	675	190	285	385	585	170	255	345	520

Client: **Clenergy Australia**
 Project: **PV-ezRack® SolarRoof Adjust. Tilt Legs Spacing Table**
 Address: **Within Australia**
 Designed: **M.A**

Job: 2078
 Date: **Feb-16**

REV K

PV-ezRack® SolarRoof Frame spacing Table for Adjustable Reverse Tilt Leg

Type of Rail ER-R-ECO
 Type of Interface ER-TL (Adjustable Tilt Leg)
 Solar Panel Dimension 2mx1m
 Terrain category 3

 Type of Interface 30°-60° Adjustable Tilt Leg
 Roof Angle (Φ) - ≤10°

Wind Region	Building Height - H (m)															
	H≤5				5<H≤10				10<H≤15				15<H≤20			
	Corner	Edge	Intermediate	Internal	Corner	Edge	Intermediate	Internal	Corner	Edge	Intermediate	Internal	Corner	Edge	Intermediate	Internal
A	705	1040	1215	1380	705	1040	1215	1380	610	935	1125	1325	545	830	1065	1280
B	510	775	1025	1280	510	775	1025	1280	440	670	910	1185	395	600	810	1115
C	315	480	645	990	315	480	645	990	275	415	560	855	245	370	500	760
D	220	330	445	675	220	330	445	675	190	285	385	585	170	255	345	520

Type of Interface 30°-60° Adjustable Tilt Leg
 Roof Angle (Φ) - ≤20°

Wind Region	Building Height - H (m)															
	H≤5				5<H≤10				10<H≤15				15<H≤20			
	Corner	Edge	Intermediate	Internal	Corner	Edge	Intermediate	Internal	Corner	Edge	Intermediate	Internal	Corner	Edge	Intermediate	Internal
A	870	1155	1295	1460	870	1155	1295	1460	750	1075	1245	1400	670	1010	1180	1355
B	625	955	1140	1425	625	955	1140	1425	540	825	1055	1320	485	735	995	1240
C	390	590	795	1105	390	590	795	1105	337	510	690	1025	300	455	615	940
D	270	405	545	830	270	405	545	830	232	350	470	715	210	315	420	640

Type of Interface 30°-60° Adjustable Tilt Leg
 Roof Angle (Φ) - ≤30°

Wind Region	Building Height - H (m)															
	H≤5				5<H≤10				10<H≤15				15<H≤20			
	Corner	Edge	Intermediate	Internal	Corner	Edge	Intermediate	Internal	Corner	Edge	Intermediate	Internal	Corner	Edge	Intermediate	Internal
A	1255	1410	1540	1765	1255	1410	1540	1765	1180	1350	1475	1680	1115	1310	1425	1620
B	1075	1340	1515	1730	1075	1340	1515	1730	995	1240	1450	1650	890	1170	1365	1590
C	710	1040	1215	1520	710	1040	1215	1520	615	940	1130	1405	550	835	1065	1325
D	485	740	1000	1245	485	740	1000	1245	420	640	865	1150	375	570	770	1085

Client: **Clenergy Australia**
 Project: **PV-ezRack® SolarRoof Adjust. Tilt Legs Spacing Table**
 Address: **Within Australia**
 Designed: **M.A**

Job: 2078
 Date: **Feb-16**
 REV K

General Notes			
Note 1	Screws minimum embedding length into timber 35 mm		
Note 2	Recommended screws		
	Metal Purlins/Battens		Fasteners to use
	0.55 mm – 1.5 mm		M6-11 TPI RoofZips
	1.9 mm		M6-11 TPI RoofZips OR 12g-14 TPI Teks screws
	2.4 mm and Above		12g-24 TPI Teks screws
	Wood purlins and Rafter		Fasteners to use
	Pine and Hardwood (35mm embedment and above)		M6 (12g) with 10 TPI
Note 3	Following components are satisfied to use according to AS1170.2011		
	Components	Part Number	Description
	MT-base Rail	ER-R-MT2560	MT-Rail 2560 mm
	Corrugated Adapter	ER-AD-C110	Adapter for corrugated iron roof
	Tilt Legs	ER-TL-30	Tilt Legs Kit fixed 30° (front and back leg)
	Hanger Bolt	ER-HB-200/WOMP	Hanger Bolt without mounting plate M10x200. Fixed to timber purlin only
	Roof extender	ER-RE-200	Roof Hook Extender 200mm
Note 4	For adjustable tilting leg, Maximum back leg angle to horizontal	-	90°
	Minimum back leg angle to horizontal	-	30°
Note 5	Refer Figure 5.3 of AS/NZS 1170.2:2012 for definition of roof zones.		
Note 6	For PV panels with length of 1700mm, increase the spacing by 15%.		

Definition of Roof Zones

1. For flush mounted systems installed on a pitched roof

Conditions:

- a. For pitched roofs where roof angle is between 1° and 30° .
- b. h/d is equal or less than 0.5 **and** h/b is equal or less than 0.5 (h = height, b =width and d = length of the building).

*If **any** of the above conditions are **not** met, please go to case 2.

Step 1: Determine the largest building dimension between the building width and length.

Step 2: Divide the **largest** value in (*Step 1*) by 3.

Step 3: Value obtained in *Step 2* represents each zone length.

Flush mounted arrays:

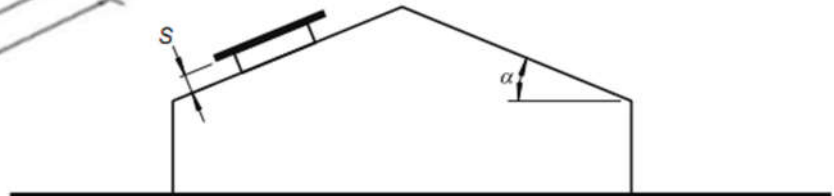
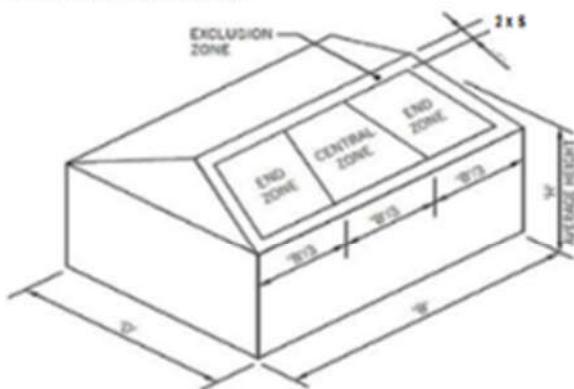
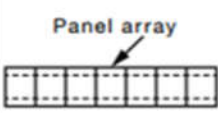

FIGURE D8 PANEL MOUNTED PARALLEL TO ROOF PLANE

Upwind end	Central	Downwind end
		

Upwind end, Downwind end = Edge
 Central, Upwind Central, Downwind
 Central = Middle

2. For flush mounted systems installed on a pitched roof

Conditions:

- a. For pitched roofs where roof angle is between 1° and 45° .

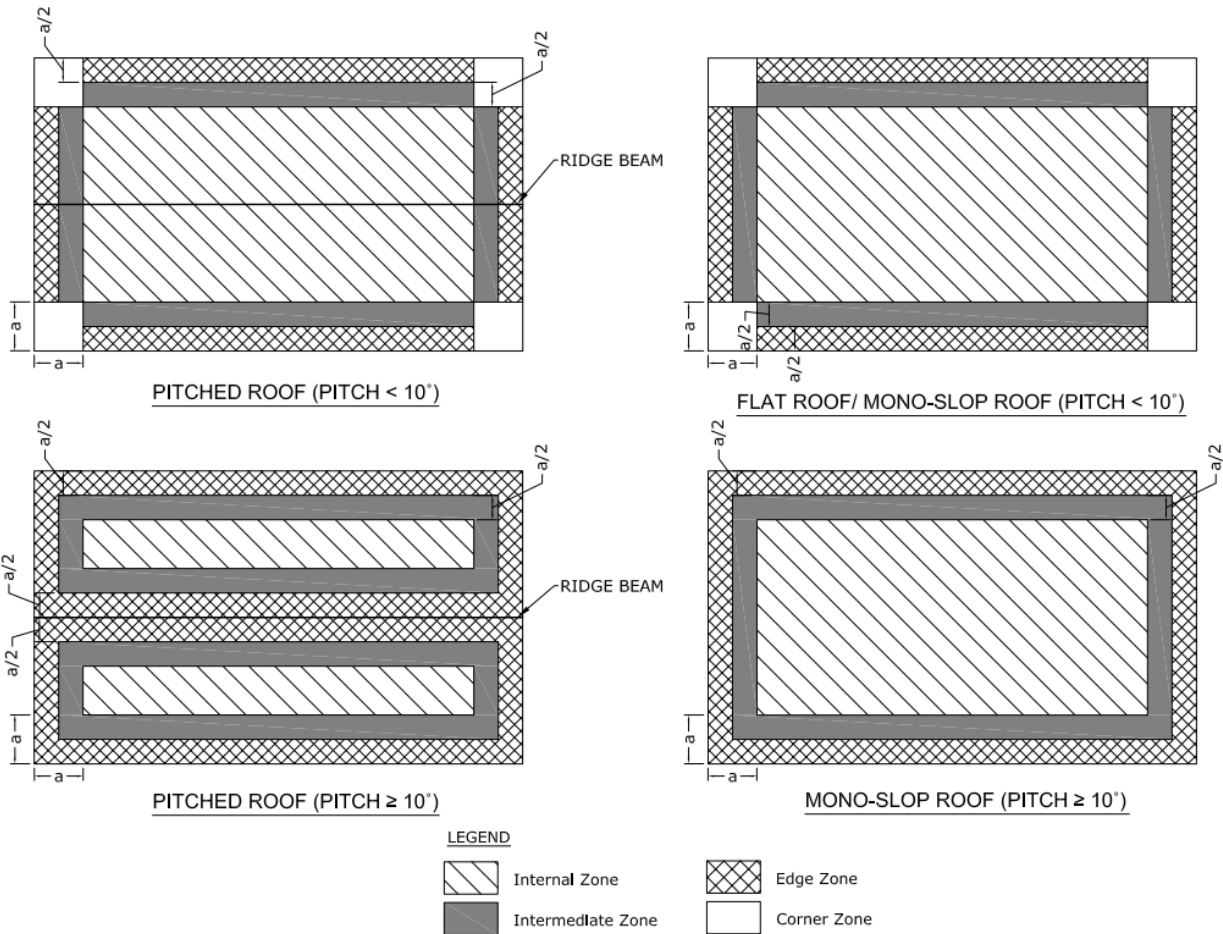

In the front figure h = height, b = width and d = length of the building.

- Step 1:* Determine building height, width and length.
Step 2: Multiply the width of the building by 0.2
Step 3: Multiply the length of the building by 0.2
Step 4: Determine **lowest** value between: (height of the building) **and** $0.2 \times$ length of the building **and** $0.2 \times$ width of the building
Step 5: The lowest value in step 4, equates to **a**.

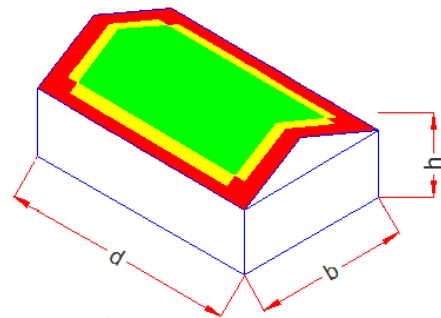

Gamcorp (Melbourne) Pty Ltd A.C.N 141 076 904 A.B.N 73 015 060 240
www.gamcorp.com.au melbourne@gamcorp.com.au
 Suite 4, 346 Ferntree Gully Rd, Notting Hill VIC 3168
 Tel: 03 9543 2211 Fax: 03 9543 4046

3. For tilt array systems

Condition:

- a. For pitched roofs where roof angle is between 1° and 45° .

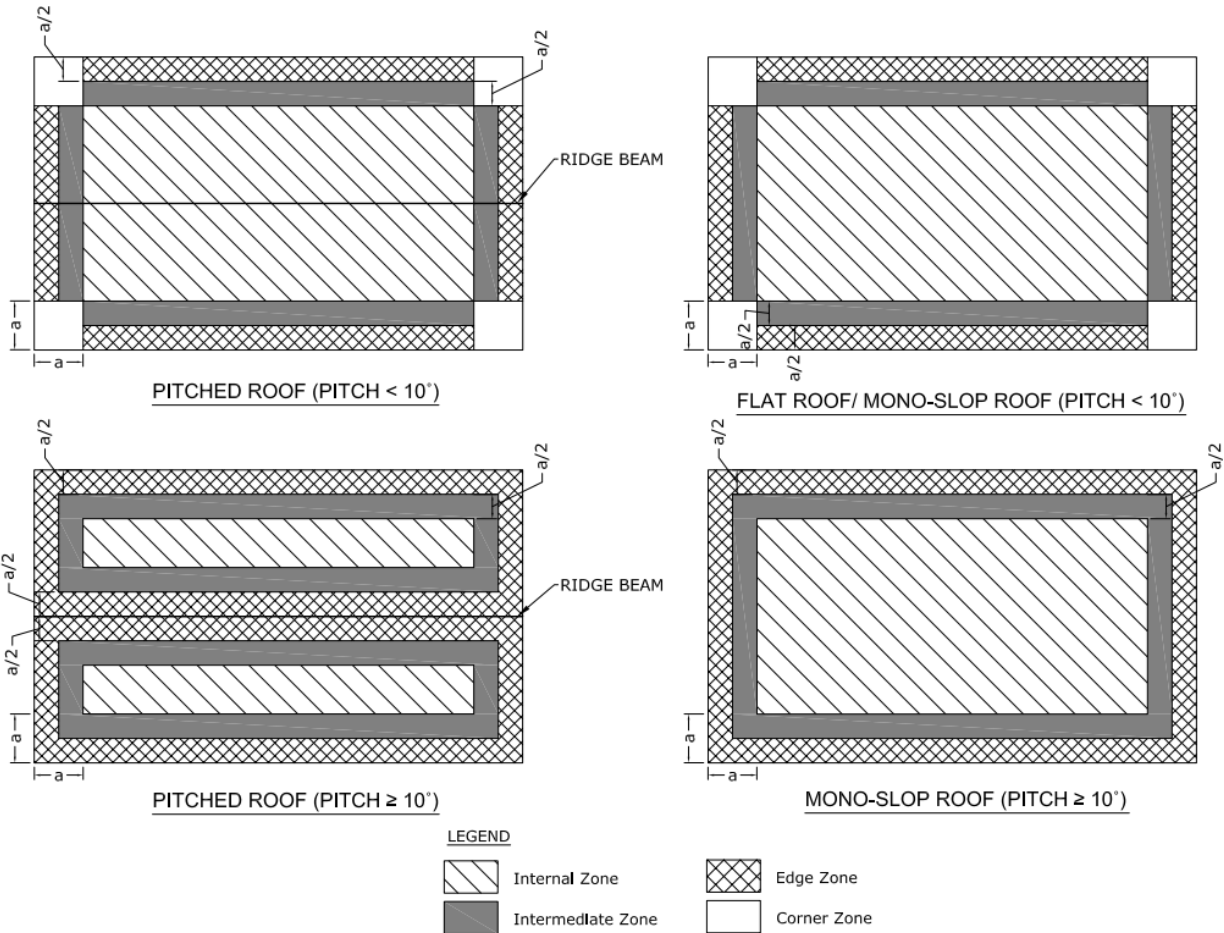

In the front figure h = height, b = width and d = length of the building.

Step 1: Determine building height, width and length.

Step 2: Multiply the width of the building by 0.2

Step 3: Multiply the length of the building by 0.2

Step 4: Determine **lowest** value between: (height of the building) **and** $0.2 \times$ length of the building **and** $0.2 \times$ width of the building

Step 5: The lowest value in step 4, equates to **a**.

